

J2 Power Supply J2PS:

J2R Scientific's experimenter's power supply (J2PS) is open source project that you can build yourself or purchase from J2R Scientific. Our power supply is small and portable. So small, in fact, you can mount it to virtually any robot or electronic project. You can even fit it in your tool box.

The J2PS will provide you with the following direct current (DC) voltage levels:

- ✦ +5Vdc
- ✦ -5Vdc
- ✦ +6Vdc
- ✦ +9Vdc
- ✦ +12Vdc
- ✦ -12Vdc
- ✦ +15Vdc

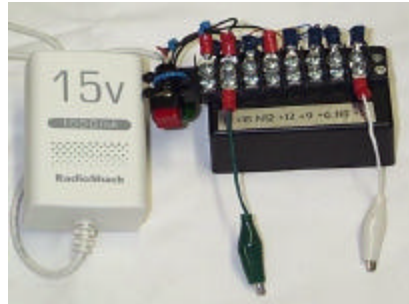

Parts required to build the J2PS are as follows:

Qty per J2PS	Source	Price	Cat. Number	Item Description
1	Digi-Key	0.52	497-1448-5-ND	L7809CV +9 Regulator
1	Digi-Key	0.70	497-1013-ND	7912 -12 Regulator
1	Digi-Key	0.64	497-1449-5-ND	7812 +12 Regulator
1	Digi-Key	0.70	497-1220-1-ND	7905 -5 Regulator
1	Digi-Key	0.52	296-11108-1-ND	7805 +5 Regulator
1	Digi-Key	0.65	497-1445-5-ND	7806 +6 Regulator
1	Radio Shack	3.99	270-0283	3 x 2 x 1 box with board
1	Radio Shack	21.99	273-1691	15V DC 1000mA Transformer
1	Radio Shack	\$3.00		Push on, Push off switch
1	Radio Shack	\$3.00		12V Light Green
1		\$4.00		8 Pos Dual Row Header
		\$5.00		Misc

Please note: You don't have to use the same regulators as I did, meaning any +5 volt regulator will work the same, but they might come in a different pack. Also keep in mind Radio Shack stores usually only carry +5v and +12v regulators.

The Radio Shack project box listed will provide a prototype circuit board inside the case, which is removable. To build this power supply you will solder all the voltage regulators into the circuit board, spacing them out around the board. Solder in jumper wires to all the positive terminals and tie all these wires to one point on the board. Do the same for the ground or common terminals to the voltage regulators, as the diagram on the follow page shows.

This diagram shows the basic wiring for the J2PS board.

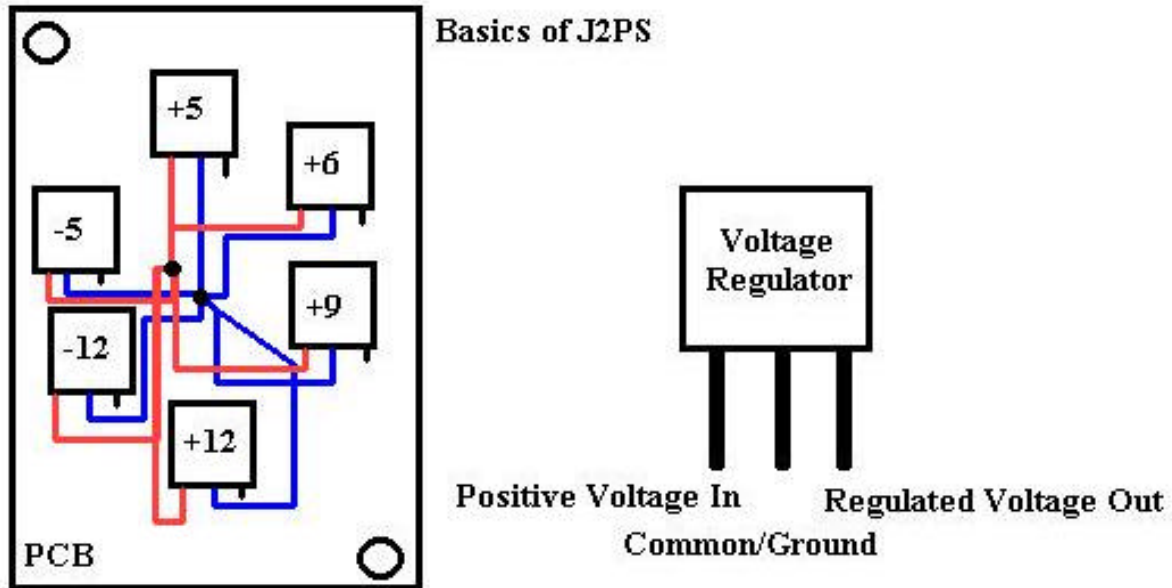

All standard voltage regulators will have the same pin out as the one shown here. Remember that the ground/common is going to the ground for both your input and output voltage. **DO NOT CONNECT AC VOLTAGE DIRECTLY TO THESE DC VOLTAGE REGULATORS.**

All the regulators now connect to a common ground and voltage input point. Run wires from these two points to a power source, which could be the 15V 1000mA transformer that I suggest. Or you can use this in an automotive application by taping into the vehicles 12V source.

I suggest wiring the two common voltage points to an 8-position dual row screw terminal, as I did. You will also want to solder wires from the out put ends of each regulator to the screw terminal. I used crimp on terminal connectors to connect to the screw terminals. You can purchase the crimp on connectors and 8-position dual row screw terminal from Radio Shack as well or order them from Digi-Key, though I do not currently have those part numbers handy.

To complete your power supply, place the PCB in the case and attach the 8-position screw terminal to the top of the case with double-sided tape or with screws. Wire in a switch between your incoming positive DC voltage and the screw terminal. I also wired in a green 12Vdc light from Radio Shack to the +12Vdc terminal and the ground so I can see when the power supply is on.

I also took alligator clips and soldered lead wires to them. At the ends of the wires I crimped on screw terminal fork connectors to attach my leads to the screw posts. With the alligator clips I can quickly connect and disconnect power to my projects.

Parts Cost: \$46 (approximately)
J2R Scientifics' Price \$65 (J2PS)
J2R Scientifics' Price w/o the transformer \$35 (J2PS-T)
Shipping and Handling \$6 in the US (J2PS-SH)

Disclaimer of Liability:

J2R Scientific accepts no responsibility implied or otherwise for the use or misuse of the robot. J2R Scientific is not responsible for any special, incidental, or consequential damages resulting from any breach of warranty, or under any legal theory, including lost profits, downtime, goodwill, damage to or replacement of equipment or property, and any costs or recovering, reprogramming, or reproduction of data associated with the use of the hardware or software produced and or sold by J2R Scientific.

J2R Scientific is not responsible for any modifications made to any of our products without the express written permission and guidance of J2R Scientific.

Warranty:

J2R Scientific warrants this product against defects in material and workmanship for a period of 90 days. If you discover a defect, we will, at our own discretion, repair, replace or refund the purchase price. We will return your product or its replacement via standard shipping. Expedited shipping is available at the customer's expense.

Any suspected damage from shipping is to be reported to J2R Scientific immediately.

Note: Physically abusing products of J2R Scientific or attempting to repair or modify our product without our guidance (such as directed in J2R Scientific manuals or via tech support from J2R Scientific), voids the warranty.